

Caden Nelms Project – Detailed view (v1)

By Bill Weis

Requirements:

1. Be able to voice control his adjustable bed
2. Caden has some lamps and other devices that are plugged into the wall which he would like to control by voice

Solution – High Level:

1. Designed a voice activated bed controller which gave Caden the ability to control the Head Up and Head Down as well as Foot Up and Foot Down functions of his adjustable bed. We also provided the means for all 6 functions including Bed Up and Bed Down to be manually controlled. He can control the bed using Alexa as well as the Google mini.
2. We provided 3 WeMo Smart Mini plugs for Caden to control the devices that are plugged into the wall.

Details of the Solution

1 – Voice Control his bed – Caden has an adjustable bed which is controlled by an HS-3 Remote. This bed is a 6-function bed which includes Head Up, Head Down, Foot Up, Foot Down, Bed Up and Bed Down. For safety reasons, Bed Up and Bed Down require use of the provided HS-3 hand held remote. The other 4 functions of Head Up/Down and Foot Up/Down can be controlled using the provided hand held remote as well as by voice commands. The voice commands can be issued through Alexa as well as through the Google Mini we provided. The benefit of being able to voice control the bed via either smart speaker is redundancy as well as to be able to compare the performance of Alexa vs Google.

Here is a Visio diagram of the solution.

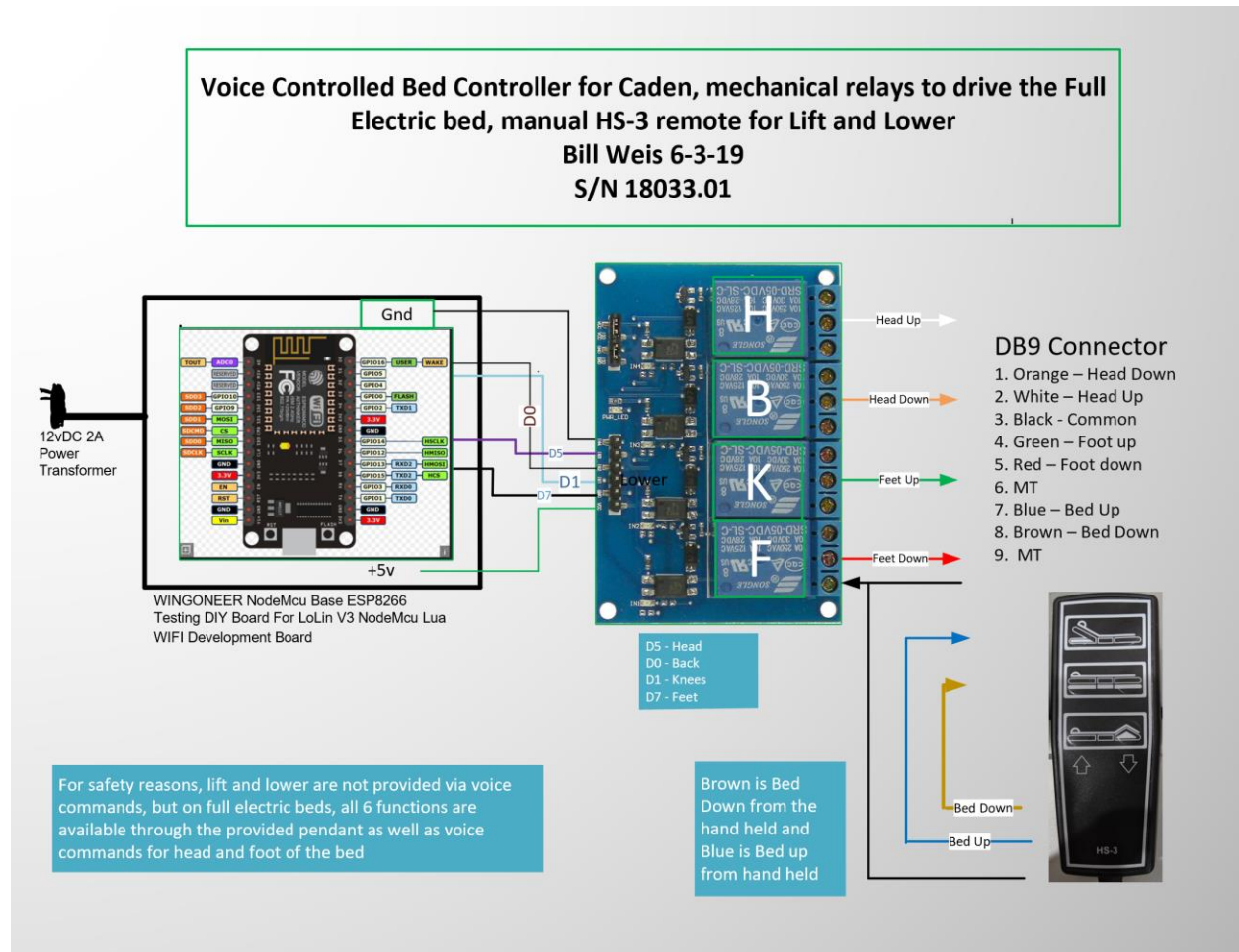

2. Turn on/off the lights in his room by voice – We provided 3 WeMo Smart Mini Plugs which Caden will be able to use to voice control devices in his room that plug into the wall including some lamps.

Resources

[Amazon Echo](#)

[Alexa Support](#) (Contact Support via the Amazon Alexa app - can have them call your number)

[Google Home getting started](#)

[Google Home Help Forum](#)

[Google Home Support](#) Phone number for Google Home hardware support = 855-971-9121 (24/7 days a week)

[Logitech Harmony Knowledge Base](#)

[Logitech Harmony Support](#) Phone # for Support = 866-601-5644 (M-F 8am to 6pm PST)

[Lifx](#)

[Wemo Support](#) Phone number for Support = 1-844-745-wemo (9366)