

Theanna Project – Detailed view (v1)

By Bill Weis

Requirements:

1. Be able to voice control her bed (Invacare Full-Electric 1115290 pendant)

Solution – High Level:

1. Installed an Amazon Echo and a Google Mini where both can control a custom developed bed controller to allow Theanna to control her Invacare bed using voice commands.

1. Be able to voice control her bed (Invacare Full-Electric 1115290 pendant)

Theanna has ALS and locating and operating the hand held remote is becoming difficult. We designed a voice activated bed controller which will give Theanna the ability to control her adjustable bed with a variety of commands. All commands run for a predetermined length of time and Theanna can choose the command that best suits her needs. The head of the bed can be raised/lowered in 3,4,5 &8 second intervals. It will require multiple commands to go from a flat position to a full up sitting position, but this approach is done for safety reasons. The foot end of the bed can be raised/lowered in 3, 4 or 5 second intervals. A nice feature of the Invacare bed design allows for us to provide a dual control environment. Both voice-activated control as well as adjustments to the bed via the pendant are possible. Thanks to the design of the Invacare bed, it is possible to have the option of providing bed control via a pendant without having to swap cables under the bed. This is handy in cases where WiFi might be disrupted or if a caregiver chooses to adjust the bed manually.

Here is a schematic of the bed controller design

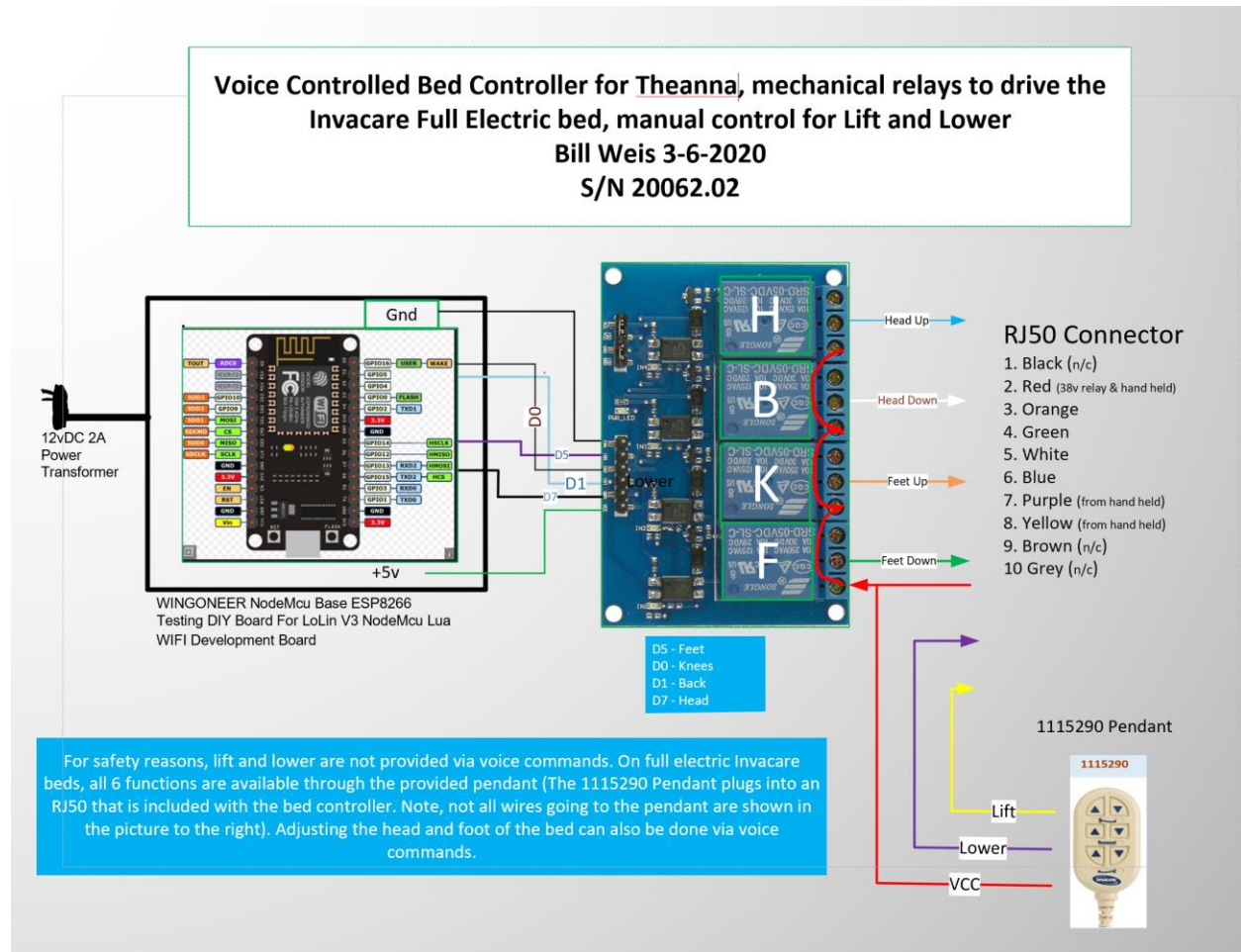

Resources

[Amazon Echo](#)

[Alexa Support](#) (Contact Support via the Amazon Alexa app - can have them call your number)

[Google Home getting started](#)

[Google Home Help Forum](#)

[Google Home Support](#) Phone number for Google Home hardware support = 855-971-9121 (24/7 days a week)

[Logitech Harmony Knowledge Base](#)

[Logitech Harmony Support](#) Phone # for Support = 866-601-5644 (M-F 8am to 6pm PST)

[Lifx](#)

[Wemo Support](#) Phone number for Support = 1-844-745-wemo (9366)